



Definition of Tire Terms

Design Rim Width: “Design Rim Width” is the specific rim width assigned to each tire size designation, to determine basic tire dimensions.

Section Width: “Section Width” is the maximum width of a new tire.

Overall Diameter: “Overall Diameter” is the diameter of an inflated tire at the outermost surface of the tread.

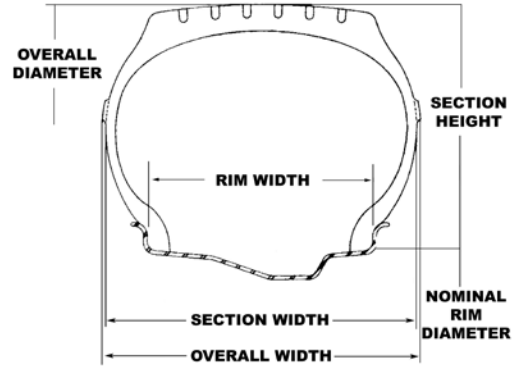

Maximum Load Capacity: “Maximum Load Capacity” is the maximum weight a tire is designed to carry, under standard use conditions.

Load Identification:

Load Range with a letter (A, B, C, etc.), **Standard Load** and **Extra Load** are used to identify a given size tire with its load and inflation limits, when used in a specific type of service.

Ply Rating is a term used to identify a given tire with its maximum recommended load, when used in a specific type of service. It is an index of tire strength and does not necessarily represent the number of cord plies in the tire.

Static Load Radius: “Static Load Radius” is the dimension from the bottom of the tire to the center line of an axle, when the tire is loaded at its rated capacity.

How The Tire Part Number System Works: Part Numbers incorporate tire sizes and descriptions, to allow you to easily determine the tires you need to order. For example, part numbers 7516BE and ST205-75-R15BC-I can be interpreted as follows:





Inches / Decimal / Metric Conversion Chart

This chart is provided for your convenience. With it you can easily convert fractions of an inch (in 1/64" increments) to decimals and metric equivalents.

Inches	Decimal	mm	Inches	Decimal	mm	Inches	Decimal	mm	Inches	Decimal	mm
1/64	0.015	0.396	17/64	0.265	6.746	33/64	0.515	13.096	49/64	0.765	19.446
1/32	0.031	0.793	9/32	0.281	7.143	17/32	0.531	13.493	25/32	0.781	19.843
3/64	0.046	1.190	19/64	0.296	7.540	35/64	0.546	13.890	51/64	0.796	20.240
1/16	0.062	1.587	5/16	0.312	7.937	9/16	0.562	14.287	13/16	0.812	20.637
5/64	0.078	1.984	21/64	0.328	8.334	37/64	0.578	14.684	53/64	0.828	21.034
3/32	0.093	2.381	11/32	0.343	8.731	19/32	0.593	15.081	27/32	0.843	21.431
7/64	0.109	2.778	23/64	0.359	9.123	39/64	0.609	15.478	55/64	0.859	21.828
1/8	0.125	3.175	3/8	0.375	9.525	5/8	0.625	15.875	7/8	0.875	22.225
9/64	0.140	3.571	25/64	0.390	9.921	41/64	0.640	16.271	57/64	0.890	22.621
5/32	0.156	3.968	13/32	0.406	10.318	21/32	0.656	16.668	29/32	0.906	23.018
11/64	0.171	4.365	27/64	0.421	10.715	43/64	0.671	17.065	59/64	0.921	23.415
3/16	0.187	4.762	7/16	0.437	11.112	11/16	0.687	17.462	15/16	0.937	23.812
13/64	0.203	5.159	29/64	0.453	11.509	45/64	0.703	17.859	61/64	0.953	24.209
7/32	0.218	5.556	15/32	0.468	11.906	23/32	0.718	18.256	31/32	0.968	24.606
15/64	0.234	5.953	31/64	0.484	12.303	47/64	0.734	18.653	63/64	0.984	25.003
1/4	0.250	6.350	1/2	0.500	12.700	3/4	0.750	19.050	1	1.000	25.400

14.5" - 17.5" Diameter Goodyear Tires



Many trailer builders require tires specifically designed for long-lasting, heavy duty applications. We have the tires to fit these needs. This group includes sizes from 14.5" up to heavy duty 17.5's.



TIRES & WHEELS

PART NO.	REF. NO.	DESCRIPTION	L.R.	O.D.	SEC. WIDTH	RIM WIDTH	MAX. LOAD CAP SINGLE / DUAL	LOAD RADIUS
800145BF	338900	800 X 14.5 LT NYLON, BLKWL	F	28.2	8.0	6.0	2790 @ 100 / 2460 @ 100	13.3
900145BF	338950	900 X 14.5 LT NYLON, BLKWL	F	28.3	9.7	7.0	3230 @ 100 / 2840 @ 100	13.3
7015BD	339200	700 X 15 NYLON, BLKWL	D	29.0	8.0	5.5	2040 @ 60 / 1820 @ 60	13.8
7516BE	339425	750 X 16 NYLON, BLKWL	E	32.2	8.7	6.0	2755 @ 75 / 2470 @ 75	14.8
LT21585R16BE	339440	LT215-85R-16, RAD, BLKWL	E	30.4	8.5	6.0	2680 @ 80 / 2470 @ 80	14.2
LT23585R16BE	339450	LT235-85R-16, RAD, BLKWL	E	31.7	9.3	6.5	3042 @ 80 / 2778 @ 80	14.8
LT23585R16BG	339510	LT235-85R-16, RAD, BLKWL	G	30.7	9.3	6.0	3750 @ 110 / 3415 @ 110	14.4
LT24575R16BE	339550	LT245-75R-16, RAD, BLKWL	E	30.5	9.8	7.0	3042 @ 80 / 2778 @ 80	14.2
875165BE	339800	8.75 X 16.5 NYLON, BLKWL	E	29.4	8.8	6.75	2680 @ 75 / 2405 @ 75	13.7
950165BE	340200	9.50 X 16.5 NYLON, BLKWL	E	30.4	9.5	6.75	3195 @ 75 / 2835 @ 75	14.1
1200165BF	340300	12 X 16.5 NYLON, BLKWL	F	31.6	12.1	9.75	4045 @ 75 / 3560 @ 75	14.9
215-75R-175H	340610	215-75R-17.5, BLKWL	H	30.5	8.8	6.75	4805 @ 125 / 4540 @ 125	14.2
245-70R-175H	340658	240-70R-17.5, BLKWL	H	31.3	10.1	7.50	6005 @ 125 / 5675 @ 125	14.4

13" - 16" Diameter Goodyear Marathon ST Tires

Realizing the need for "extra capacity" tires to fit the demanding applications of many Marine, Utility and R.V. trailers, Goodyear offers Marathon "ST" Radial Trailer Tires. Technical information is provided below.

PART NO.	REF. NO.	DESCRIPTION	L.R.	O.D.	SEC. WIDTH	RIM WIDTH	MAX. LOAD CAP SINGLE / DUAL	LOAD RADIUS
ST175-80-R13BC	337850	ST175/80R13 RADIAL TIRE	C	24.0	6.9	5.0	1360 @ 50	11.2
ST205-75-R14BC	338260	ST205/75R14 RADIAL TIRE	C	26.1	7.9	5.5	1760 @ 50	12.1
ST215-75-R14BC	338285	ST215/75R14 RADIAL TIRE	C	26.6	8.5	6.0	1870 @ 50	12.8
ST205-75-R15BC	338340	ST205/75R15 RADIAL TIRE	C	27.1	7.9	5.5	1820 @ 50	12.6
ST225-75-R15BC	338462	ST225/75R15 RADIAL TIRE	C	28.3	8.7	6.0	2150 @ 50	13.0
ST225-75-R15BD	338490	ST225/75R15 RADIAL TIRE	D	28.3	8.7	6.0	2540 @ 65	13.0
ST235-80-R16BE	338530	ST235/80R16 RADIAL TIRE	E	30.8	9.3	6.5	3420 @ 80	14.0



Value Priced Medium Truck Tires



For medium duty towing, these value priced truck tires offer rugged durability and full manufacturers' warranties.

PART NO.	REF. NO.	DESCRIPTION	L.R.	O.D.	SEC. WIDTH	RIM WIDTH	MAX. LOAD		LOAD RADIUS
							SINGLE / DUAL		
215-75R-175H-I	340600	TUBELESS STLBLT RADIAL	H	30.2	8.3	6	4,805 @ 125 / 4,540 @ 125		14.2
235-75R-175J-I	340655	TUBELESS STLBLT RADIAL	H	31.4	9.2	6.75	6,005 @ 125 / 5,675 @ 125		14.7

Radial Trailer Tires

TIRES & WHEELS



Built from the ground up for trailering, these blackwall radials are designed for a quiet ride and smooth handling. Great value and national warranty coverage.

PART NO.	REF. NO.	DESCRIPTION	L.R.	O.D.	SEC. WIDTH	RIM WIDTH	MAX. LOAD		LOAD RADIUS
							CAPACITY		
ST175-80-R13BC-I	337840	ST175-80-R13, BLACKWALL	C	24.0	7	5.00	1360 @ 50		11.2
ST205-75-R14BC-I	338250	ST205-75-R14, BLACKWALL	C	26.1	8	5.50	1760 @ 50		12.2
ST205-75-R15BC-I	338330	ST205-75-R15, BLACKWALL	C	27.0	8	5.50	1820 @ 50		12.6
ST225-75-R15BD-I	338480	ST225-75-R15, BLACKWALL	D	28.3	8.8	6.00	2540 @ 65		13.1
ST235-80-R16BE-I	338520	ST235-80-R16, BLACKWALL	E	30.8	9.8	6.50	3520 @ 80		14.3
LT23585R16BE-I	339435	235-85-R16, BLACKWALL	E	31.7	9.8	6.50	single wheel cap: 3,080 @ 80 dual wheel cap: 2,780 @ 80		14.7

Bias Ply Trailer Tires



Our line of bias ply trailer tires offers the perfect balance of product performance and value. These tires are competitively priced and are backed by a nationwide manufacturer's warranty.

PART NO.	REF. NO.	DESCRIPTION	L.R.	O.D.	SEC. WIDTH	RIM WIDTH	MAX. LOAD		LOAD RADIUS
							CAP SINGLE		
ST175-80-D13BC-V	337830	ST175-80-R13 BIAS TIRE, BLACKWALL	C	24.4	7.0	5	1360 @ 50		11.1
ST205-75-D14BC-V	338236	ST205-75-D14 BIAS TIRE, BLACKWALL	C	26.5	7.9	5.5	1760 @ 50		12.0
ST205-75-D15BC-V	338320	ST205-75-D15 BIAS TIRE, BLACKWALL	C	27.1	8.0	5.5	1820 @ 50		12.5
ST225-75-D15BD-V	338442	ST225-75-D15 BIAS TIRE, BLACKWALL	D	28.3	8.8	6	2540 @ 65		12.9
7015BD-V	339110	7.00-15 IMPORT BIAS PLY TIRE	D	29.6	8.0	5.5	2040 @ 60		13.7
7516BE-V	339422	7.50-16 IMPORT BIAS PLY TIRE	E	31.8	8.8	6.0	2755 @ 75		14.6



Small Diameter Tire and Wheel Assemblies



We offer 8", 10" and 12" Tire and Painted Wheel Assemblies for many applications; all are available with 4 on 4" or 5 on 4.5" bolt patterns. Many are also available on Galvanized Wheels.



TIRES & WHEELS

PART NO.	REF. NO.	LOAD RANGE	O.D.	SEC. WIDTH	TIRE SIZE	MAX LOAD CAP.	MAX PSI	FINISH
480TW4-B	341800	B	16.1	4.6	4.80-8	590	60	PAINTED
480TW4GV-B	341900	B	16.1	4.6	4.80-8	590	60	GALVANIZED
480TW5-B	342000	B	16.1	4.6	4.80-8	590	60	PAINTED
480TW5GV-B	342100	B	16.1	4.6	4.80-8	590	60	GALVANIZED
578TW4-B	342200	B	18.1	5.8	5.70-8	715	75	PAINTED
578TW5-B	342400	B	18.1	5.8	5.70-8	715	75	PAINTED
578TW5GV-C	342410	C	18.0	5.9	5.70-8	910	100	GALVANIZED
165-65-D8BB-5	342455	B	16.7	6.6	165/65-8	620	45	PAINTED
215-60-8TW4-B	342472	B	18.4	8.9	215/60-8	780	35	PAINTED
215-60-8TW5-B	342477	B	18.4	8.9	215/60-8	780	35	PAINTED
215-60-8TW4-C	342482	C	18.3	8.9	215/60-8	935	50	PAINTED
215-60-8TW5-C	342485	C	18.3	8.9	215/60-8	935	50	PAINTED
215-60-8TW5GV-C	342490	C	18.3	8.9	215/60-8	935	50	GALVANIZED
205-65-D10BB-5	342810	B	20.8	8.3	205/65-10	910	35	WHITE
205-65-D10BC-5	343010	C	20.5	8.3	205/65-10	1100	50	WHITE
205-65-D10BC-5GV	343060	C	20.5	8.3	205/65-10	1100	50	GALVANIZED
205-65-D10BD-5	343145	D	20.6	8.3	205/65-10	1330	70	WHITE
205-65-D10BD-5GV	343155	D	20.6	8.3	205/65-10	1330	70	GALVANIZED
205-65-D10BE-5GV	343170	E	20.4	8.4	205/65-10	1650	90	GALVANIZED
205-65-D10BE-5	343220	E	20.4	8.4	205/65-10	1650	90	WHITE
5312TW5-C	343300	C	21.9	5.6	530-12	1045	80	WHITE SPOKE
4812TWSPK4-B	343600	B	20.5	4.8	4.80-12	785	60	PAINTED
4812TWSPK4GV-B	343700	B	20.5	4.8	4.80-12	785	60	GALVANIZED
4812TWSPK5-B	344000	B	20.5	4.8	4.80-12	785	60	PAINTED
4812TWSPK5GV-B	344010	B	20.5	4.8	4.80-12	785	60	GALVANIZED
4812TWSPK5GV-C	344015	C	20.5	4.8	4.80-12	990	90	GALVANIZED



Custom Trailer Wheels

Our wheels are designed, manufactured and tested to provide service and performance that is the standard of the industry. These wheel designs are subjected to destructive “torture” testing to simulate extreme service and overload conditions. Spoke and Modular wheels not only offer a custom look, they have capacities that meet or exceed the O.E.M. design and are economical to use.

Wheel Selection How-To's

A great deal of thought and consideration should be given when selecting trailer wheels. Important choices must be made from the various wheels on the market. When combining wheels, tires, hubs and axles, the load carrying capacity is limited to whichever component has the lowest rating. Load capacities relate specifically to generally accepted standard axle applications for conventional trailers used in normal highway service, loaded equally side-to-side. Unusual axle configurations, unequal fore and aft loading, or overload conditions can cause premature failure of wheels, tires and/or other parts.

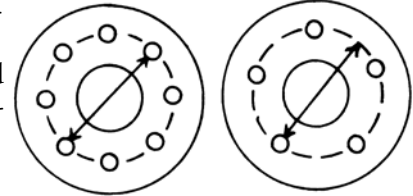

Even

Odd

How To Determine Bolt Pattern:

Match wheels to hubs by the number of bolts and bolt circle. To determine the bolt circle on wheels with an even number of bolt holes, measure center-to-center on bolt holes directly across from each other on the diameter (Example: 8 on 6 1/2 would mean 8 bolt holes with 6 1/2” center-to-center diameter). On odd number bolt wheels, measure any bolt hole center to the point halfway between bolt holes on the diameter (Example: 5 on 4 1/2 would mean 5 bolt holes with 4 1/2” measure to a point halfway between the opposite bolts).

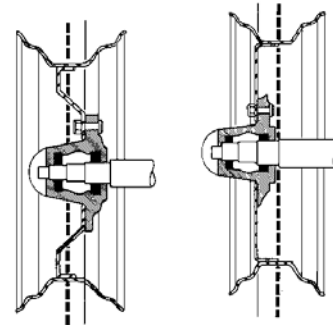

Outset

Inset

How to Determine Wheel Offset:

Offset is the distance between the mounting face of the disc and rim centerline.

Inset: Refers to the distance when the mounting face is outboard of the rim centerline.

Outset: Refers to the distance when the mounting face is inboard of the rim centerline.

Modular Trailer Wheels

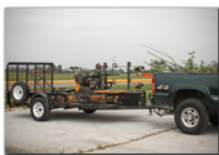

PART NO.	REF. NO.	DIA. & WIDTH	CAPACITY	OFFSET	BOLT PATTERN	PILOT DIA.	PAINT COLOR	STUD SIZE
WH1345-5WM	326025	13" X 4.5"	1660@65	0	5 ON 4 1/2	3.19	WHITE	1/2"
17-230-7	326030	14" X 5.5"	1870@50	0	5 ON 4 1/2	3.19	WHITE	1/2"
17-230-19	326032	14" X 5.5"	1870@50	0	5 ON 4 1/2	3.19	SILVER	1/2"
17-231-19	326033	15" X 5"	1820@50	0	5 ON 4 1/2	3.19	SILVER	1/2"
WH1155-550SM	326034	15" X 5"	2050@50	0	5 ON 5	3.30	SILVER	1/2"
17-231-7	326035	15" X 5"	1820@50	0	5 ON 4 1/2	3.19	WHITE	1/2"
WH1155-550WM	326036	15" X 5"	2050@50	0	5 ON 5	3.30	WHITE	1/2"
WH1155-5SM	326037	15" X 5"	2050@50	0	5 ON 4 1/2	3.30	SILVER	1/2"
17-377-7	326038	15" X 5"	1820@50	0	5 ON 5	3.19	WHITE	1/2"
17-377-19	326039	15" X 5"	1820@50	0	5 ON 5	3.19	SILVER	1/2"
17-232-7	326040	15" X 6"	2050@75	0	5 ON 4 1/2	3.19	WHITE	1/2"
17-232-19	326062	15" X 6"	2050@75	0	5 ON 4 1/2	3.19	SILVER	1/2"
17-233-7	326050	15" X 6"	2830@80	0	6 ON 5 1/2	4.27	WHITE	1/2"
WH1156-6SM	326060	15" X 6"	2850@65	0	6 ON 5 1/2	4.27	SILVER	1/2"
17-255-7	326065	16" X 6"	3050@90	0	6 ON 5 1/2	4.27	WHITE	1/2"
17-255-19	326068	16" X 6"	3050@90	0	6 ON 5 1/2	4.27	SILVER	1/2"
WH166-8WM	326070	16" X 6"	3750@110	0	8 ON 6 1/2	4.90	WHITE	9/16"
17-281-7	326075	16" X 6"	3750@110	.50 IN	8 ON 6 1/2	4.90	WHITE	9/16"
WH166-8SM	326077	16" X 6"	3750@110	0	8 ON 6 1/2	4.90	SILVER	9/16"
17-281-19	326078	16" X 6"	3750@110	.50 IN	8 ON 6 1/2	4.90	SILVER	9/16"
17-280-7	326085	16.5" X 6.75"	3530@90	.50 IN	8 ON 6 1/2	4.90	WHITE	9/16"



White Spoke Wheels

PART NO.	REF. NO.	DIA. & WIDTH	CAPACITY	OFFSET	BOLT PATTERN	PILOT DIA.	STUD SIZE
17-213-7	326095	12" X 4"	1250@90	0	4 ON 4	2.84	1/2"
17-214-7	326100	12" X 4"	1250@90	0	5 ON 4 1/2	3.19	1/2"
WH1345-4WS	326160	13" X 4.5"	1100@50	0	4 ON 4	2.82	1/2"
17-189-7	326200	13" X 4.5"	1660@65	0	5 ON 4 1/2	3.19	1/2"
17-142-7	326225	14" X 5.5"	1870@50	0	5 ON 4 1/2	3.19	1/2"
17-143-7	326230	15" X 5"	1820@50	0	5 ON 4 1/2	3.19	1/2"
WHI155-550WS	326232	15" X 5"	2050@50	0	5 ON 5	3.3	1/2"
17-384-12	326233	15" X 5"	1820@50	0	5 ON 5	3.19	1/2"
17-149-7	326235	15" X 6"	2050@75	0	5 ON 4 1/2	3.19	1/2"
WHI156-550WS	326256	15" X 6"	2640@65	0	5 ON 5	3.3	1/2"
WHI156-5475WS	326260	15" X 6"	2640@65	0	5 ON 4 3/4	3.3	1/2"
17-144-7	326275	15" X 6"	2830@80	0	6 ON 5 1/2	4.27	1/2"
17-243-7	326290	16" X 6"	3050@90	0	6 ON 5 1/2	4.27	1/2"
17-162-7	326300	16" X 6"	3750@110	0	8 ON 6 1/2	4.9	9/16"
17-163-7	326375	16.5" X 6.75"	3530@90	0	8 ON 6 1/2	4.9	9/16"



Chrome Wheels

Chrome Wheels have all of the features and benefits of Painted Wheels, plus a bright chrome plated finish. Available in eight spoke or 10-hole modular versions.

PART NO.	REF. NO.	DIA. & WIDTH	CAPACITY	STYLE	OFFSET	BOLT PATTERN	PILOT DIA.	STUD SIZE
WH1345-5CS	327620	13" X 4 1/2"	1660@65	SPOKE	0	5 ON 4 1/2	3.19	1/2"
WH146-5CS	327800	14" X 6"	1900@50	SPOKE	0	5 ON 4 1/2	3.30	1/2"
WH146-5CM	327900	14" X 6"	1900@50	MOD	0	5 ON 4 1/2	3.30	1/2"
WH156-5CS	328000	15" X 6"	2640@65	SPOKE	0	5 ON 4 1/2	3.30	1/2"
WH156-6CS	328200	15" X 6"	2850@80	SPOKE	0	6 ON 5 1/2	4.29	1/2"
WH166-8CS	328400	16" X 6"	3760@110	SPOKE	0	8 ON 6 1/2	5.15	9/16"
WH166-8CM	328500	16" X 6"	3760@110	MOD	0	8 ON 6 1/2	5.15	9/16"



TIRES & WHEELS

Galvanized Spoke Trailer Wheels

These galvanized spoke wheels are perfect for salt water marine trailers or any situation that demands added corrosion resistance. Choose the size that best fits your needs.

PART NO.	REF. NO.	DIA. & WIDTH	CAPACITY	OFFSET	BOLT PATTERN	PILOT DIA.	STUD SIZE
WH1345-5GVS	328700	13" X 4 1/2"	1660@65	0	5 ON 4 1/2	3.19	1/2"
WH146-5GVS	328720	14" X 6"	1900@50	0	5 ON 4 1/2	3.30	1/2"
WH156-5GVS	328740	15" X 6"	2640@65	0	5 ON 4 1/2	3.30	1/2"
WH156-6GVS	328750	15" X 6"	2850@80	0	6 ON 5 1/2	4.29	1/2"
WH166-6GVS	328770	16" X 6"	3050@90	0	6 ON 5 1/2	4.29	1/2"
WH166-8GVS	328780	16" X 6"	3750@110	0	8 ON 6 1/2	5.15	9/16"

New Marine Items!



Utility Rims

Many utility trailers have been equipped with "UTG" or utility type axles that require a 14.5" diameter rim. We have 2 widths available, 6.00" and 7.00". These rims are specifically manufactured for trailer use.

PART NO.	REF. NO.	DIA. & WIDTH	CAPACITY	BOLT PATTERN
R145-6	333005	14.5" X 6"	3200@110	RIM
R145-7	333020	14.5" X 7"	3230@100	RIM





Aluminum Trailer Wheels

These great looking mods, stars, directional, "Series 06" & "Series 07" spoke design wheels have been built from the ground up, specifically for trailer use. They all feature steel hole inserts and are individually boxed. A wet clear coat finish ensures long lasting corrosion resistance. All are covered by a 3 year limited manufacturer's warranty.

PART NO.	REF. NO.	DIA. & WIDTH	CAP / PSI	OFFSET	BOLT PATTERN	PILOT DIA.	DESIGN	STUD SIZE
WH135-5SA	326600	13"X5"	1660@65	0	5 ON 4 1/2	3.19	STAR	1/2"
WH135-507A	326610	13"X5"	1660@65	0	5 ON 4 1/2	3.19	SERIES 07	1/2"
WH1455-5A	326700	14"X5.5"	1900@60	0	5 ON 4 1/2	3.19	MOD	1/2"
WH1455-5SA	326705	14"X5.5"	1900@60	0	5 ON 4 1/2	3.19	STAR	1/2"
WH1455-506A	326707	14"X5.5"	1900@60	0	5 ON 4 1/2	3.19	SERIES 06	1/2"
WH1455-507A	326708	14"X5.5"	1900@60	0	5 ON 4 1/2	3.19	SERIES 07	1/2"
WH155-507A	326709	15"X5"	1820@50	0	5 ON 4 1/2	3.19	SERIES 07	1/2"
WH156-5A	326710	15"X6"	2150@60	0	5 ON 4 1/2	3.19	MOD	1/2"
WH156-506A	326713	15"X6"	2150@60	0	5 ON 4 1/2	3.19	SERIES 06	1/2"
WH156-5SA	326715	15"X6"	2150@60	0	5 ON 4 1/2	3.19	STAR	1/2"
WH156-5DA	326717	15"X6"	2150@60	0	5 ON 4 1/2	3.19	DIRCTNL	1/2"
WH156-6A	326720	15"X6"	2830@65	0	6 ON 5 1/2	4.25	MOD	1/2"
WH156-606A	326723	15"X6"	2830@65	0	6 ON 5 1/2	4.13	SERIES 06	1/2"
WH156-6SA	326725	15"X6"	2830@65	0	6 ON 5 1/2	4.25	STAR	1/2"
WH156-6DA	326727	15"X6"	2830@65	0	6 ON 5 1/2	4.25	DIRCTNL	1/2"
WH156-607A	326728	15"X6"	2830@65	0	6 ON 5 1/2	4.25	SERIES 07	1/2"
WH167-6A	326730	16"X7"	3200@80	.31 OUT	6 ON 5 1/2	4.25	MOD	1/2"
WH167-6SA	326735	16"X7"	3200@80	.19 IN	6 ON 5 1/2	4.25	STAR	1/2"
WH166-607A	326737	16"X6"	3200@80	0	6 ON 5 1/2	4.25	SERIES 07	1/2"
WH167-8A	326740	16"X7"	3200@80	.31 OUT	8 ON 6 1/2	5.15	MOD	1/2"
WH167-806A	326743	16"X7"	3200@80	0	8 ON 6 1/2	4.90	SERIES 06	1/2"
WH167-8SA	326745	16"X7"	3200@80	.19 IN	8 ON 6 1/2	5.15	STAR	1/2"
WH167-8DA	326747	16"X7"	3200@80	0	8 ON 6 1/2	5.15	DIRCTNL	1/2"
WH166-807A	326750	16"X6"	3960@110	0	8 ON 6 1/2	4.9	SERIES 07	9/16"
WH175675-8MAK	326800	17.5"X6.75"	4850@130	0	8 ON 6 1/2	4.9	MOD	9/16"
WH175675-8MAKHD	326820	17.5"X6.75"	6050@130	0	8 ON 6 1/2	4.77	MOD HD	5/8"
LA-341316	333385	3/4"-13/16"	LUG ADAPTER FOR SERIES 06 ALUM. WHLs					

TIRES & WHEELS

O.E.M. Single Wheels

O.E.M. design wheels have been the standard used on trailers for many years. They offer the appearance, strength and simplicity that many customers prefer. We offer O.E.M. design wheels in sizes from 8" to 17.5" diameter.

PART NO.	REF. NO.	DIA. & WIDTH	CAPACITY	OFFSET	BOLT PATTERN	PILOT DIA.	HUB CAP	STUD SIZE
WH84-40E	321800	8"X3.75"	900@100	0	4 ON 4	2.50	1102	1/2"
WH84-50E	322000	8"X3.75"	900@100	0	5 ON 4 1/2	2.89	1102	1/2"
WH106-40E	322200	10"X6"	1200@110	0	4 ON 4	2.50	1102	1/2"
WH106-50E	322400	10"X6"	1200@110	0	5 ON 4 1/2	2.81	1102	1/2"
WH1345-50E	323200	13"X4.5"	1480@50	.50 IN	5 ON 4 1/2	2.62	1308	1/2"
WH1455-50E	323400	14"X5.5"	1870@50	.50 IN	5 ON 4 1/2	2.62	1308	1/2"
WH155-50E	323600	15"X5"	1820@50	.50 IN	5 ON 4 1/2	2.62	1308	1/2"
WH156-50E	323625	15"X6"	1820@75	.50 IN	5 ON 4 1/2	2.62	1308	1/2"
WH156-60E	323800	15"X6"	2600@75	0	6 ON 5 1/2	3.65	1306	1/2"
WH166-60E	324200	16"X6"	3050@90	0	6 ON 5 1/2	3.65	1309	1/2"
17-153	324400	16"X6"	3750@110	.50 IN	8 ON 6 1/2	4.89	1309	9/16"
17-154	324600	16.5"X6.75"	3530@90	.50 IN	8 ON 6 1/2	4.89	1309	9/16"
WH165975-8HD	324650	16.5"X9.75"	4200@75	.50 IN	8 ON 6 1/2	4.78	N/A	5/8"
WH175675-80E.19IN	325000	17.5"X6.75"	6200@125	.19 IN	8 ON 6 1/2	4.75	N/A	5/8"
WH175675-80E.31OUT	325420	17.5"X6.75"	6200@125	.31 OUT	8 ON 6 1/2	4.75	N/A	5/8"
WH175675-80E.50OUT	325428	17.5"X6.75"	6200@125	.50 OUT	8 ON 6 1/2	4.75	N/A	5/8"



O.E.M. Dual Wheels

Because of the increasing use of dual wheel axles, it has become very important that we be able to supply our customers with wheels that complement the axles and tires used in any given application.

We feel the group of Dual Wheels listed below will fit your needs. We offer dual wheels in diameters from 14.5" to 22.5", with various designs and capacities.

PART NO.	REF. NO.	DIA. & WIDTH	CAPACITY	OFFSET	BOLT PATTERN	PILOT DIA.	STUD SIZE
WHDD145700-80E	328800	14.5"X7"	3000@100	5.65 OUT	8 ON 6 1/2	4.75	5/8"
17-279	329500	16"X6"	3100@110	5.50 OUT	8 ON 6 1/2	4.75	5/8"
WHIDS166-80E	329540	16"X6"	3500@110	5.50 OUT	8 ON 6 1/2	4.75	5/8"
WHFD166-80E	329600	16"X6"	2500@110	5.00 OUT	8 ON 6 1/2	4.89	5/8"
WHHD166-80E	329675	16"X6"	2500@110	5.00 OUT	8 ON 6 1/2	4.90	5/8"
17-157	330200	16.5"X6.75"	3000@80	5.50 OUT	8 ON 6 1/2	4.75	5/8"
WHD175675-275-80E	330500	17.5"X6.75"	6200@125	5.60 OUT	8 ON 275mm	221mm	5/8"
WHD175675-100E	330600	17.5"X6.75"	6200@125	6.19 OUT	10 ON 8 3/4	6.50	5/8"
WHD225825-100E	330800	22.5"X8.25"	7800@120	6.625 OUT	10 ON 11 1/4	8.718	5/8"



QuickTrim® ABS Trailer Hub Covers & Wheel Liners

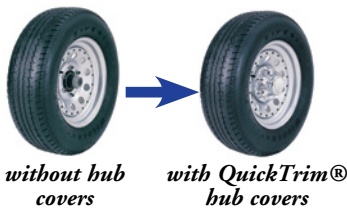

QuickTrim® ABS Chrome Hub Covers & Wheel Liners offer a quick and cost effective way to dress up your trailer wheels. Features include easy snap-on installation and five convenient sizes. Hub Covers are also available in low cost black ABS plastic.



TIRES & WHEELS

PART NO.	REF. NO.	BOLT PATTERN	COLOR	LUG/WHEEL SIZE
QT545C	335395	5 ON 4 1/2	CHROME	1/2"
QT655C	335420	6 ON 5 1/2	CHROME	1/2"
QT655B	335425	6 ON 5 1/2	BLACK	1/2"
QT765C	335430	8 ON 6 1/2	CHROME	13/16"
QT865C	335440	8 ON 6 1/2	CHROME	7/8"
QT544CLO	335500	5 ON 4 1/2	CHROME ABS	14"
QT545CLO	335510	5 ON 4 1/2	CHROME ABS	15"
QT655CLO	335515	6 ON 5 1/2	CHROME ABS	15"
QT6556CLO	335520	6 ON 5 1/2	CHROME ABS	16"
QT865CLO	335525	8 ON 6 1/2	CHROME ABS	16"



Wheel Simulators

Dress up your plain trailer wheels with these great looking wheel simulators. All are made of mirror finish stainless steel for a long lasting shine.



Won't rust! Easy to install! No special tools required!



PART NO.	REF. NO.	DESCRIPTION	WHEEL SIZE	FINISH
GQST50	335100	SNAP-ON (SET OF 4)	15"	STAINLESS STEEL
NST06	335125	DOT BOLT ON (4/SET)	16"/16.5"	STAINLESS STEEL
NDT165	335145	DUAL BOLT-ON (4/SET)	16"/16.5"	STAINLESS STEEL
GDST175	335160	BOLT ON (SET OF 4)	17.5"	STAINLESS STEEL
GQ64	335180	DUALY TRUCKS SNAP-ON (4/SET)	16"	STAINLESS STEEL
PGD168LNT	335190	JAM NUT W/LUG NUT COVER		



Center Caps

Many people want to add the “finishing touch” to their wheels. One sure way is to add a Center Cap. Available in chrome-plated steel or stainless steel, this unique design can be used with standard axles or with E-Z lube axles, by simply removing a replaceable plug.



PART NO.	REF. NO.	DESCRIPTION	FINISH	WHEEL CENTER PILOT SIZE
CCP-60C	335650	ABS CENTER CAP PLUG ONLY	CHROME	N/A
295EZ	335750	CENTER CAP W/PLUG	CHROME	2.95"
319EZ	336005	CENTER CAP W/PLUG	CHROME	3.19"
319EZ-SS	336020	CENTER CAP W/PLUG	STAINLESS STEEL	3.19"
330EZ	336170	CENTER CAP W/PLUG	CHROME	3.30"
425EZ	336410	CENTER CAP W/PLUG	CHROME	4.25"
425EZ-SS	336450	CENTER CAP W/PLUG	STAINLESS STEEL	4.25"
482EZ	336750	CENTER CAP W/PLUG	CHROME	4.82"
490EZ-SS	336815	CENTER CAP W/PLUG	STAINLESS STEEL	4.90"
5125EZ	336825	CENTER CAP W/PLUG	CHROME	5.125"
5125EZ-SS	336830	CENTER CAP W/PLUG	STAINLESS STEEL	5.125"

TIRES & WHEELS

Chrome Hub Caps

Chrome Hub Caps have been an industry standard for many years. They are a fine choice to complement O.E.M. design wheels.

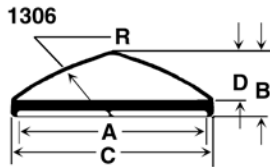

A = Flange diameter (I.D.)
 B = Overall Height
 C = Overall Width
 D = Crown Height
 R = Crown Radius

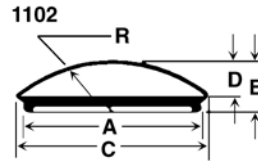

A = Flange diameter (O.D.)
 B = Overall Height
 C = Overall Width
 D = Crown Height
 R = Crown Radius



PART NO.	REF. NO.	WHEEL SIZE	A	B	C	D	R
1102	333700	8, 12, 13-4 BOLT	7.66	2.56	8.25	1.97	5.50
1302	333800	15", 5 ON 4.5"	8.74	2.41	9.03	1.60	7.13
1306	334000	15	10.2	3.05	10.62	2.37	CONE
1308	334600	13, 14, 15	9.23	2.62	9.62	1.87	7.00
1309	335000	16, 16.5	11.66	2.81	12.22	2.12	11.00

Chrome & Stainless Steel Wheel Nuts

These popular wheel nuts fit 1/2" or 9/16" diameter studs.



12SSLN

916CLN

PART NO.	REF. NO.	DESCRIPTION
12CLN	337000	1/2" CHROME BULGE STYLE WHEEL NUT W/RIGHT HAND THREAD
12CLN-L	337005	1/2" CHROME LUG NUT, 1 3/4" LONG, BULGE STYLE
12SSLN	337008	1/2" STAINLESS CAPPED ACORN 1 PIECE BULGE
916CLN	337020	9/16" CHROME ACORN WHEEL NUT W/ RIGHT HAND THREAD



Lug Wrenches

These lug wrenches offer versatility and great value. Both are chrome plated for long lasting durability and good looks. The 20" Cross Lug Wrench fits 17mm, 3/4", 13/16" and 7/8" nuts.

The telescoping Power Lug Wrench includes 2 reversible sockets that fit 13/16", 7/8", 17mm & 19mm nuts.



PART NO.	REF. NO.	DESCRIPTION
LW433	333375	20" CROSS LUG WRENCH (17MM,3/4",13/16",7/8")
LW405	333380	POWER LUG WRENCH W/COMBO SOCKETS13/16,7/8&17-19MM

TIRES & WHEELS

Valve Stems

Every wheel needs a stem and we have the one you need. A metal valve stem is required when inflation pressure exceeds 65 PSI.



PART NO.	REF. NO.	DESCRIPTION
TR413	337200	(SMALL BASE - .453" HOLE) RUBBER SNAP-IN 65 PSI MAX
TR415	337400	(LG. BASE - .625" HOLE) RUBBER SNAP-IN 65 PSI MAX
TR416	337600	METAL FOR PRESSURES OVER 100 PSI (.453" & .625" HOLES)
501SW	337650	METAL, OUTER MOUNT FOR ALUMINUM WHEELS W/PRESSURE OVER 100 PSI (.453" & .625" HOLES)
TR572	337700	METAL, 3 3/4" LONG, PRESSURE OVER 100 PSI (LG. BASE, .625" HOLE)
TR600	337750	(SMALL BASE, .453" HOLE) METAL W/RUBBER SNAP-IN UP TO 100 PSI
TR600C	337755	(SMALL BASE, .453" HOLE) RUBBER/METAL SNAP-IN W/CHROME SLEEVE & CAP, UP TO 100 PSI
TR801	337800	(LG. BASE, .652" HOLE) METAL W/RUBBER SNAP-IN/UP TO 100 PSI

Packaged Wheel Locks



PART NO.	REF. NO.	DESCRIPTION
RG01-150	139980	1/2" WHEEL LOCK SET, INCLUDES 2 LOCKS & 1 KEY



Slime Tire Sealant & Supplies



Slime Tire Sealant has been specially formulated for use in tubeless tires. Once installed into the tire, Slime will instantly seal punctures in the tread area up to 1/4”.



- Non Aerosol
- Non Toxic & Non Corrosive
- Cleans up easily with water
- Non Flammable
- Works up to 2 years

HOW SLIME WORKS

Slime seeks out and instantly seals tread area punctures using Fibro-Seal Technology. Microfibers in our patented formula are carried by the escaping air to the puncture where they build up to form a plug that stops air loss.

TIRES & WHEELS



SDS-1000/06
32 oz.



SDS-500/06
16 oz.



SDS-250/06
8 oz.



SDSB-1G/02
1 Gal.



CRK0305
Combines a 16 oz. bottle of Slime and a 300 psi, 12v. air compressor; all in a zippered vinyl case.

S2040



PART NO.	REF. NO.	DESCRIPTION
SDS-250/06	333210	SLIME BRAND TIRE SEALANT, 8 OZ
SDS-500/06	333220	SLIME BRAND TIRE SEALANT, 16 OZ
SDS-1000/06	333230	SLIME BRAND TIRE SEALANT, 32 OZ
SDSB-1G/02	333240	SLIME BRAND TIRE SEALANT, 1GAL JUG W/PUMP
S2040	333360	SLIME DELUXE TIRE REAMER/PLUGGER KIT
CRK0305	333370	SMART SPAIR TIRE REPAIR KIT W/SLIME & AIR PUMP