

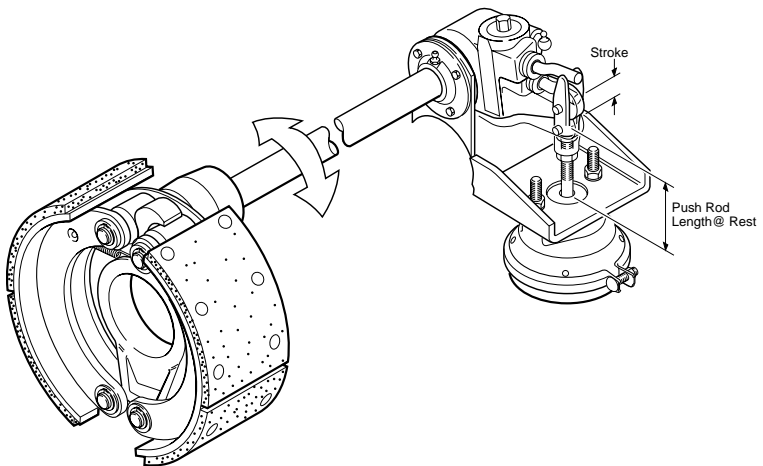

S-Cam Air Brakes

Operation

Trailer air brakes are operated by the tractor air supply through a series of relay and check valves. When braking is desired, the air is supplied to the axle air chamber which applies a force that is multiplied by the slack adjuster lever arm length. This force is transmitted rotationally through the camshaft which, through the geometry of the S-head, spreads the brake shoes to contact the brake drum surface. The air brake systems are an effective, very durable braking system for use in high mileage or extreme operating conditions. They can be outfitted with ABS (anti-lock brake systems), automatic slack adjusters and spring brakes to comply with Federal Motor Vehicle Safety Standard Part 571.121.



Air Brake Components

Air Chambers

The air chambers convert the compressed air into a mechanical force on the slack adjuster. The force on the slack adjuster operates on the end of the lever and converts the chamber output force to a torque on the S-cam. Federal and state regulations state the maximum pushrod stroke length as an indication of brake adjustment. This stroke is shown by the maximum stroke indicator located on the air chamber pushrod. Maximum allowable stroke is achieved when the indicator is fully extended from the air chamber housing.

Note: Due to manufacturing tolerances, some brakes may not meet the maximum stroke length in the “green” state and may require several burnish stops to allow the brake shoes to conform to the drum diameter.

Spring Brake

For parking and emergency braking purposes, a spring brake chamber can be used in conjunction with the standard air chamber. The spring brake contains an additional air diaphragm and a very strong spring. When air is applied to the spring brake, the spring is held in the off position by the air diaphragm. When the air is exhausted, the spring provides the braking force to the air chamber pushrod, thus actuating the brakes.

CAUTION

Do not disassemble the spring brake! It contains a compressed spring that may cause injury if removed. The spring brake must be caged before servicing and should only be performed by qualified personnel.





Slack Adjusters

The air brake slack adjusters perform two functions: (1) The slack adjuster acts as a lever arm to convert the linear pushrod force to rotational camshaft torque. The length of the slack adjuster determines the amount of torque multiplication provided from the pushrod. (2) Allows a simple external adjustment of the lining to drum clearance to compensate for shoe lining wear.

There are two types of slack adjusters, manual and automatic:

Manual slack adjusters

The manual slack adjusters require manual adjustment to compensate for the brake lining wear and the associated drum to lining gap that results. Adjustment is usually performed by rotating the hex adjusting nut on the slack adjuster body to set a lining to drum clearance of about .020-.030". See instructions for manual slack adjustment procedure.

Automatic slack adjuster

The automatic slack adjuster (ASA) maintains an optimum clearance between the brake lining and the drum by automatically adjusting on the return stroke during brake application. Various brands of ASA's may work differently. The initial adjustment and set-up of the ASA's is critical to proper function of the air brake. See instructions for slack adjuster procedure.

Note: Automatic slack adjusters are required on some commercial trailers over 26,000 lbs., manufactured after 10/20/94 per FMVSS Part 571.121. **DO NOT REPLACE AUTOSLACKS WITH MANUAL SLACK ADJUSTERS ON THESE TRAILERS.**

S-Cams

The S-cams rotate from the torque applied by the slack adjusters, resulting in spreading the brake shoes which applies the braking force to the drum. The S-cams are supported by two nylon, grease lubricated bushings. Due to the high forces exerted on the cam bushings, periodic inspection, lubrication and maintenance is required to achieve proper braking performance.

Brake Shoes

The air brake shoes are the final link in the braking system. The brake shoes are supported by pins inserted into the brake spider, and rollers that contact the S-cam surface. The shoes have a replaceable lining riveted to them. The linings have two different blocks, designated Cam and Anchor side. The brake shoes on your Dexter axle are specifically designed for that axle. Only Dexter authorized parts should be used for replacement since there are small dimensional differences between air brake parts suppliers that can significantly affect the function of the brake.



CAUTION

Improperly fitted brake parts can cause brakes to malfunction and cause loss of braking and/or wheel lockup. Loss of braking can cause an accident resulting in injuries or death.

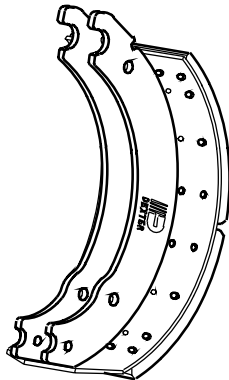



General Maintenance/Adjustment

Brake Component Lubrication

Camshaft bushings

Lubricate with approved grease through the grease fittings at the spider and camshaft support bracket locations. Apply just enough grease so grease is visible flowing past camshaft bushing seals. During this process it is advisable to grab the camshaft and shake the camshaft to see if there is excessive clearance in the camshaft bushings due to wear.

Camshaft roller journals and brake anchor pins

These components are to be lubricated with a high temperature anti-seize grease upon disassembly, maintenance and reassembly.

Manual and automatic slack adjusters

Lubricate with Lithium base NLGI Grade 1 anti-wear grease with rust and oxidizer additives applied at intervals of 3 to 6 months or 50,000 miles or per slack adjuster manufacturer's recommendations.

For Manual Slack Adjusters

Lubricate with NLGI2

For Automatic Slack Adjusters

Lubricate with ASA manufacturers

recommended lubricant

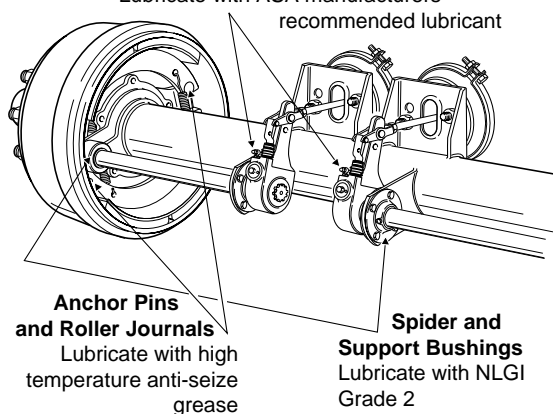

12¹/₄" Quick Change Brakes - PQ

Recommended Disassembly

1. Block and secure trailer on adequate capacity jack stands. Follow trailer manufacturers recommendations for lifting and supporting the unit. Check that the wheel and drum rotate freely.
2. Release brake and back off slack adjuster.
3. Remove wheel equipment.
4. Lift top shoe upward to disengage the shoe webs from the anchor pin. Remove anchor pin.
5. Repeat procedure 4 for the bottom shoe.
6. Remove brake keeper springs.
7. Unwrap bottom shoe by pivoting the shoe on the camshaft head and twisting the shoe 90° under the spindle. Remove shoe assemblies from spider.
8. Remove slack adjuster lock ring, disconnect slack clevis, and then remove slack adjuster.
9. Remove camshaft lock ring, spacer washer(s) and camshaft.
10. Completely inspect all brake components, servicing as necessary.

Recommended Reassembly

1. Install new camshaft bushing. Ream bushing to 1.505/1.515 if required. Install camshaft seals into the spider.

Note: When installing camshaft seals, the seal on the slack adjuster side is installed with seal facing into spider. This allows grease to purge outside the brake assembly when greasing the camshaft bushing. It also aids to avoid damage of the seal lip when camshaft is installed.

2. Install new cam roller assemblies onto the brake shoes.

Note: The head of roller pin should face the camshaft "D" washer once shoes are installed on spider.





3. Install “D” shaped camshaft washer onto the camshaft.
4. Install the camshaft into the spider. Install 005-075-00 washer and lock ring retainer on the camshaft before sliding the camshaft through the camshaft support bracket.
5. Install the slack adjuster and 005-134-00 washer and 069-078-00 lock ring retainer for 28 spline camshafts or 005-075-00 washer and 069-020-00 lock ring retainer for 10 spline camshafts.
6. Lubricate cam roller notches with anti-seize lubricant prior to installing cam roller assemblies onto the brake shoes. Bend roller retainer loop down so that retainer will be at same level as the shoe table and will not interfere with the brake drum during the life of the lining blocks.
7. Install “W” shaped retractor spring retainer pin into the 0.50" diameter shoe web holes near the camshaft roller end of the shoe.
8. Install retractor spring between shoes. Place top shoe onto spider as in service. Pivot bottom shoe on the camshaft head and twist the shoe 90° under the spindle, properly placing shoe on the spider as in service.
9. Install two (2) keeper springs on the anchor end of the shoes.
10. Lubricate anchor pin bores and shoe anchor pins with antiseize lubricant.
11. Repeat procedure 10 for the bottom shoe.
12. Lift top shoe upwards to clear anchor pin hole. Install anchor pin.
13. Connect slack adjuster to brake chamber pushrod.

Note: Always use new springs when servicing brakes.
Always use Dexter shoes when replacing shoes.

Air Brake Automatic Slack Adjustment

Mounting and adjustment procedure

If available, use installation template per manufacturer's directions. If template is not available, use the following procedure:

1. Install air chamber with proper push rod length.
2. Install the slack onto the camshaft.
3. Adjust the slack arm up to the point where the slack arm starts to engage into the clevis slot.
4. Take the ½" diameter pivot pin, and place it into the clevis slot. Hold in place (at this point, the pin is like a shim).
5. Continue adjusting the slack arm back against the pin.
6. When the slack arm touches the pin, the slack rotation will stop. The camshaft will start to rotate as you keep adjusting the slack with the wrench.
7. Continue adjusting with the wrench, which is now bringing the shoes into closer contact with the drum.
8. As you continue to adjust, spin the drum by hand to get a feel for the brake drag.
9. Adjust until the drum stops.
10. Adjust an additional ¼ to ½ turn of the wrench.
11. Pull slack away by hand, from the pin.
12. Remove the pin from the clevis slot.
13. Align ½" holes.
14. Insert ½" pin.
15. Make sure the drum rotates one (1) full revolution. If it did, proceed to step sixteen (16). If it did not rotate one revolution, remove the air chamber and slack. Start over at step one (1). Do not tighten the adjuster hex nut as tight as previously done.
16. Insert the ¼" pin.
17. Install and secure the cotter pins in the clevis and adjuster pins.





CAUTION

To insure brakes meet Federal performance requirements, Dexter Axle recommends that only original equipment premium grade linings be used. Failure to use proper linings can result in poor braking and cause accidents and injuries.

Air Brake Manual Slack Adjustment

1. Grease cam bracket and spider fittings.
2. Adjust the slack adjuster until the brake lining comes into contact with the brake drum.
 - A. For green brakes, there should be a slight amount of wheel drag at initial adjustment to compensate for any lining irregularities such as high spots.
 - B. For burnished or broken-in brakes, back off the slack adjuster to achieve .010" clearance between the drum and shoes.
3. Apply brakes using normal truck operating pressure (80-90 psi).

Note: A "green brake" is an unground, unburnished, brake. Normal manufacturing tolerances dictate that there is a break-in period required after which the lining will seat into the brake drum. During this break-in period, the user must be aware that additional brake adjustment will be mandatory to achieve optimum braking performance.

CAUTION

USE OF AIR PRESSURE IN EXCESS OF 130 PSI COULD RESULT IN FAILURE OF THE AIR CHAMBER OR SPRING BRAKE CHAMBER.

4. Check the amount of push rod travel at the clevis pin. The stroke should be as follows:

Chamber Type	Maximum Stroke
9	1½"
12	1½"
16	1½"
20	1¾"
24	1¾"
30	2"

5. With air pressure applied to brakes, check for lining to drum contact. The contact should approach 100%. Use a .010" feeler gage if in doubt. It should not fit between the lining and drum during brake application.
6. Release air pressure from the brakes and confirm that all brakes release to the normal relaxed position.
- A. When properly adjusted, the angle between the push rod and the slack adjuster should be approximately 90° +/- 5° when the brakes are applied.
- B. Proper maximum stroke should be achieved after adjusting the autoslack. Reference the push rod stroke length chart.





Introduction to Troubleshooting

Proper brake function is critical to the safe operation of any vehicle. A properly installed air brake system should not require any special attention with the exception of routine maintenance as defined by the manufacturer. If problems occur, the entire tow vehicle/trailer braking system should be analyzed by a qualified mechanic.

To assure safe operation and maximum durability of parts such as brake linings and tires, it is necessary to position and install the axle properly. It is recommended that the axle assembly be installed so that camshafts rotate in the same direction as the wheels. Installation in which the camshaft rotation is opposite that of wheel rotation could cause noisy brakes, chatter, and wheel “hop”. With this thought in mind, the axle should be ordered with placement of air chamber and slack adjuster assemblies that will insure the correct directional rotation of the camshafts when the axle is installed.

It is the responsibility of the axle installer to adjust the brakes properly. The recommended adjustment procedure is covered in the section pertaining to brakes.

Please consult the following troubleshooting charts to determine the causes and solutions for common problems found in trailer braking systems.

Troubleshooting

SYMPTOM	CAUSES	REMEDIES
No Brakes	S-Cam Flipped	Replace Linings and Drum If Needed
	Air System Malfunction	Troubleshoot per System Mfgr's Directions
	Brakes Out of Adjustment	Adjust Brakes
	Air Lines Kinked or Broken	Replace
	Slack Adjuster Broken	Repair or Replace
	Air Chamber Malfunction	Replace
Weak Brakes	Brakes Out of Adjustment	Adjust
	Excessive Drum Wear	Replace Drums
	Excessive Lining Wear	Replace Linings
	Oil Soaked Linings	Replace Linings
	Overloaded Trailers	Use Proper Load
	Air System Malfunction	Troubleshoot per System Mfgr's Directions
	Wrong Size Air Chamber	Use Correct Size Air Chamber for Application
	Worn Anchor Pin Bushings or Camshaft Bushings	Replace Bushings
Harsh Brakes	Brake Adjustment Not Correct	Adjust
	Oil on Linings	Replace Linings
	Wrong Brake Component	Use Only Approved Dexter Components





Troubleshooting

SYMPTOM	CAUSES	REMEDIES
Brake Lock-Up	Cams Froze in Park Position	Replace Camshaft Bushings
	Wrong Size Air Chamber	Use Correct Size Air Chamber
	Incorrect Slack Adjuster Length	Use Correct Length Slack Adjuster
	Air System Timing Malfunction - Too Low Relay Valve - Crack Pressure - Quick Release Valve Malfunction	Troubleshoot per System Mfg's Directions
	S-Cam Flipped Due to Brake Lining Wear	Replace Linings, Adjust
	Broken Return Springs	Determine Cause of Breakage and Replace
Surging Brakes	Grease or Oil on Linings	Replace Linings
	Out of Round or Cracked Drums	Turn or Replace Drums
Overheating Brakes	Linings Dragging Due to Weak or Broken Return Spring	Replace Return Springs
	Wrong Component in Brake	Use Only Dexter Approved Components
	Bearing Adjustment	Re-adjust
	Air System Malfunction Sticky Valves, Dirt, etc.	Troubleshoot per System Mfg's Directions
	Improper Mounting of Air Chamber and Slack Adjuster	Mount per Recommended Procedure
	Camshaft or Shoes Frozen	Replace Bushing