



Installation Instructions

**Model 213
Chevy/GMC**
Fits 1988-2000 **Classic Body Style**
LONG BED ONLY - 1/2, 3/4 & 1 Ton
Does Not Fit 1988-1991 Crew Cab

LONG BED ONLY



Model 213

FOR THE SAFEST INSTALLATION

WARNING Most pick up trucks have **FUEL LINES** and/or **BRAKE LINES** and/or **ELECTRICAL WIRING** positioned along the truck frame rails where your Flip-Over hitch will install. **BEFORE INSTALLATION** identify and examine the location of fuel lines, brake lines and electrical wires. Be sure you will not damage fuel lines, brake lines or electrical wiring when positioning the hitch components, drilling holes or tightening fasteners. **Be Certain To Avoid Fuel Tanks When Drilling Holes.**

- Wear Safety Glasses, Gloves and Particle Mask for protection while installing a Flip-Over gooseneck hitch.
- ALWAYS correctly chock tires prior to raising truck with jacking device. For protection in case of jacking device failure ALWAYS use Jack Stands when working under or around a truck which has been raised by a jacking device.
- Allow the exhaust system to cool prior to installation to avoid possible burns from hot tail pipe and muffler.
- Torque ALL fasteners used in the Flip-Over gooseneck hitch installation as specified in these Installation Instructions.

INSTALLATION PROCEDURE

1. Mark and center punch a location 49-3/4" (49.75") from the rear of the truck bed (tailgate end) centered between the wheel wells. Use a 3-1/2" hole saw to cut a hole in the bed floor centered at this location. Grind or file the hole edges smooth and clean all saw tailings from the bed area before proceeding. Remove the spare tire.
2. If using a vehicle hoist, raise the truck at this time. If using a jacking device Chock the front tires to prevent the truck from rolling. Jacking against the rear bumper or frame, lift the rear of the truck approximately 10". It is not necessary to lift the rear tires off the ground. Properly position jack stands under the rear frame of the truck to protect against jack failure.
3. If there is a heat shield located above the tail pipe at the rear axle it must be removed. Replace any screws used to secure any sections of heat shield not removed.
4. Identify the Front Cross Member (2), the longest of the two angles. With the plain side (2" leg) up and with the slotted side (2-1/2") facing the rear of the truck, slide the Cross Member across the frame rails of the truck. Position the Cross Member across the frame rails about 4" forward of the 3-1/2" hole.
5. Place the Rear Cross Member (1) across the frame rails similarly, with the plain side (2" leg) up and with the slotted side facing forward. Position the Rear Cross Member about 4" behind of the 3-1/2" hole.
6. Lift the Ball Assembly (3) into position between the Cross Members with the pin retracting mechanism on the driver side and with the protruding tube passing into the 3-1/2" hole. With an overhead lifting device or a saw horse in the bed of the truck, use cable or rope to hold the Center Assembly firmly against the underside of the bed floor. Fasten the Center Assembly to the Cross Members by passing eight 1/2" X 1-1/2" bolts from inside the Center Assembly channel, and fitting with a flat washer and nut over the slotted holes. **Pull the slack out of the bolts but do not tighten at this time.**
7. Use a muffler cutter or similar tool to grind both 1/4" bolts which extend through the frame rail on the driver side which hold the brake line brackets flush with the frame web.
8. Square the assembled Cross Members and Center Assembly across the frame. Identify the Driver Side (4, with labels) and Passenger Side (5) Frame Plates. Position the Frame Plate extensions between the Cross Members and fasten using four 1/2" X 1-1/2" bolts with flat washers and nuts. **Pull the slack out of the bolts but do not tighten at this time.**
9. Fasten the Frame Plates to the frame by aligning two of the holes lower in the Frame Plate with existing holes in the truck frame. **Note: On some trucks factory holes may be missing and it may be necessary to drill 1/2" holes in the truck frame. Pass 1/2" X 1-1/2" bolts with flat washers from inside the frame and secure with 1/2" nuts. . Pull the slack out of the bolts but do not tighten at this time.**
10. Tighten the fasteners holding the Cross Members to the Center Assembly. Square the assembly across the frame and tighten the fasteners holding the Frame Plates to the frame and tighten the fasteners holding the Cross Members to the Frame Plates.

Torque all fasteners to 65 foot pounds.

continued

INSTALLATION PROCEDURE - CONTINUED

- From the driver side, pass the Actuating Rod (6) through the 1/2" hole (NOT the slotted hole) between the Frame Plate extensions and into the linkage coupler. Align the Actuating Rod so the set screw seats in the hole provided in the rod, and tighten to 7 foot pounds. Be certain the Actuating Rod rotates freely and be certain it moves in and out freely. **NOTE:** It may be necessary to deform the lip formed by the inner fender and bed floor to create clearance for the Actuating Rod.
- Drill four 1/2" holes for the Safety Chain Brackets from under the truck bed. Drill through the **INNER** four 9/16" holes in the Ball Assembly through the truck bed floor. Remove all tailings. Place a U-bolt in each pair of holes from the top side of the bed. From under the bed place a spring and 1/2" lock nut on each U-bolt leg. Tighten each nut until thread extends through the nut.
- Place a thin film of lithium grease inside the ball socket, on the base of the ball and on the hitch ball.
- Retract the Retaining Pin by rotating the Actuating Rod 90 degrees counter clockwise. Place the Flip-Over ball in the Socket. Rotate the Actuating Rod 90 degrees clockwise to engage the Retaining Pin.
- Please read the **SAFE TOWING INSTRUCTIONS** on the Flip-Over WARRANTY sheet.

Flip-Over OPERATION & MAINTENANCE

- To invert the Flip-Over ball, retract the retaining pin by rotating the actuating rod 90 degrees counter clockwise. After inverting the Flip-Over ball in the Socket, rotate the actuating rod 90 degrees clock wise to engage the retaining pin.
- Keep the base of the Flip-Over ball lightly lubricated with lithium grease. If the Flip-Over ball becomes difficult to free from socket, lubricate with WD-40 or similar aerosol lubricant.

Hardware Provided

- 16 - 1/2" X 1-1/2" Grade 8 Bolts
- 16 - 1/2" Lock Nuts
- 28 - 1/2" Flat Washers
- 2 - U-Bolts
- 4 - Springs

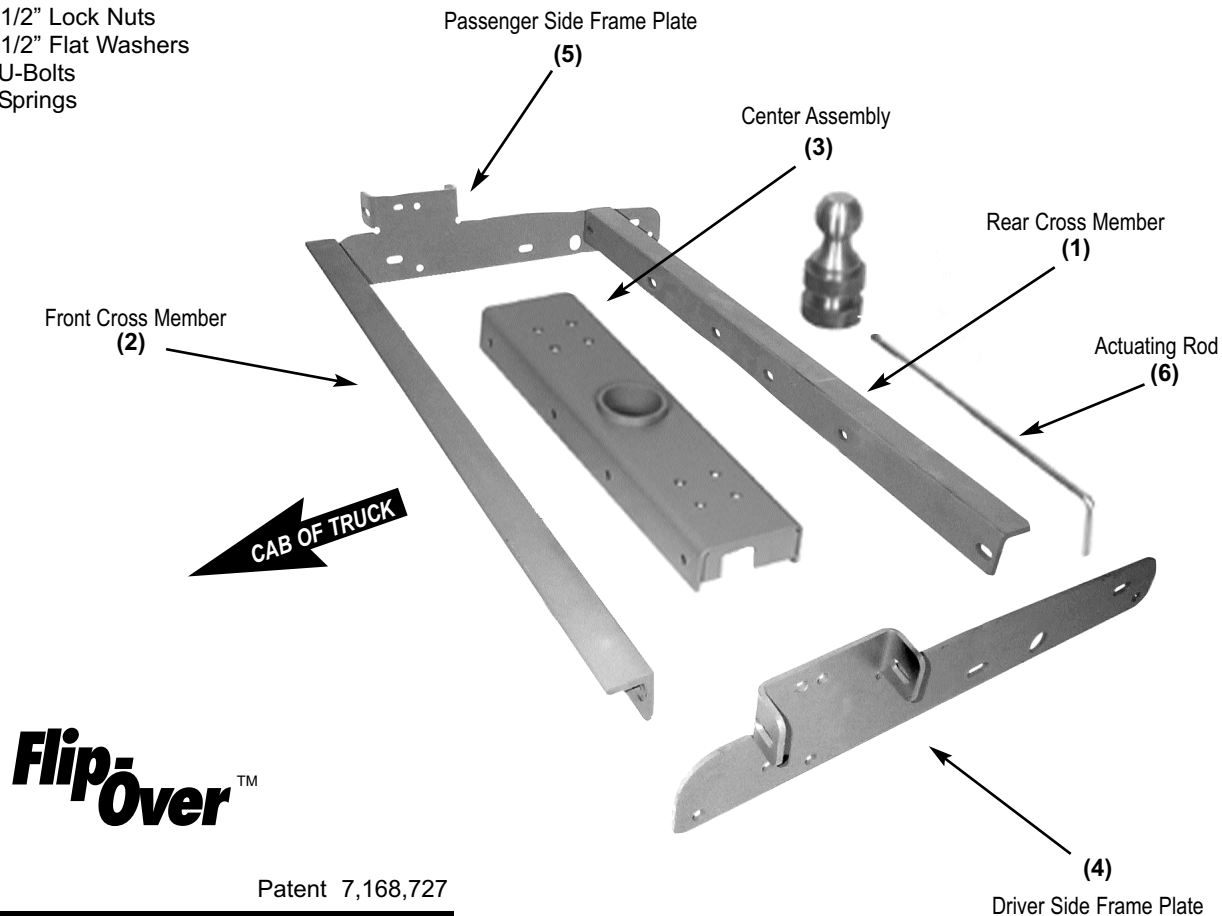

Model Number 213
Gross Trailer Weight: 30M lbs.
Gross Trailer Tongue Weight: 7.5M lbs.

Young's Products, LLC
www.popuphitch.com 800-837-8578

