

Installation Instructions

Model 120 Ford F-150

Fits 2004-2006 1/2 Ton ONLY
Long and Short Bed



PopUpTM
Retractable Hitch Ball

Safari Industrial Park
4330 Johnson Road
Chanute, KS 66720
800-837-8578
US Patent 6,447,000

MODEL 120 11/05 FOR THE SAFEST INSTALLATION

WARNING Most pick up trucks have **FUEL LINES** and/or **BRAKE LINES** and/or **ELECTRICAL WIRING** positioned along the truck frame rails where your PopUp hitch will install. **BEFORE INSTALLATION** identify and examine the location of fuel lines, brake lines and electrical wires. Be sure you will not damage fuel lines, brake lines or electrical wiring when positioning the hitch components, positioning or tightening U-bolts. **Be Certain To Avoid Damage To Fuel Lines and/or Wiring When Positioning and Tightening U-Bolts.**

- Wear Safety Glasses, Gloves and Particle Mask for protection while installing a PopUp gooseneck hitch.
- ALWAYS correctly chock tires prior to raising truck with jacking device. For protection in case of jacking device failure ALWAYS use Jack Stands when working under or around a truck which has been raised by a jacking device.
- Allow the exhaust system to cool prior to installation to avoid possible burns from hot tail pipe and muffler.
- Torque ALL fasteners used in the PopUp gooseneck hitch installation as specified in these Installation Instructions.

INSTALLATION PROCEDURE

WARNING: Verify adequate trailer swing clearance between trailer nose and cab of truck, and trailer and rear of truck.

1. Mark and center punch a location 47-9/16" from the rear lip of the truck bed floor (tailgate end) centered between the wheel wells. Use a 3" hole saw to cut a hole in the bed floor centered at the correct location. File or sand the edges of the hole to remove any burrs. Before proceeding, remove all saw tailings from the bed area.
2. Remove the spare tire. If using a vehicle hoist, raise the truck at this time. If using a jacking device Chock the front tires to prevent the truck from rolling. Jacking against the rear bumper or frame, lift the rear of the truck approximately 10". It is not necessary to lift the rear tires off the ground. Properly position jack stands under the rear frame of the truck to protect against jack failure.
3. Front and Rear Cross Members (1 and 2) are identical. Slide the Front Cross Member across the frame rails through the driver side wheel well forward of the rear axle with the plain side (2" leg) up and with the slotted side (2-1/2" leg) facing rearward. Position the Forward Cross Member about 2" forward of the hole in the bed floor.
4. Slide the Rear Cross Member across the frame rails from the driver side wheel with the plain side (2" leg) up and with the slotted side (2-1/2" leg) facing the front of the truck. Position the Cross Member approximately square across the frame rails and about 5" behind the hole in the bed floor.
5. The Frame Plates mount to the frame rails using U-bolts. Identify the Driver Side Frame Plate (4, with the decal). Position the Driver Side Frame Plate against the outside of the frame with the bent tab against the truck shock mount tube. (Be sure the Front Cross Member is ahead of the front cross member securing tab on the Frame Plate, and be sure the rear cross member is rearward of the rear cross member securing tab.)

Place a 3/8" plate washer in the bottom of a medium size U-bolt and slide this U-bolt over the shock mount tube and through the holes in the bent tab at the front of the Frame Plate. (See Illustration "A") Start a 1/2" lock nut on both legs of the U-bolt. Leave these fasteners very loose at this time. Pass a large U-bolt over the frame from the inside and through the holes in the rear portion of the Frame Plate. Start 1/2" lock nuts on both legs of the U-bolt. Leave these fasteners very loose at this time.

Repeat this procedure to install the Passenger Side Frame Plate.

6. With the ball down, and with the cam facing the front of the truck, raise the Ball Assembly (3) into position between the Cross Members placing the 3" tube in the hole cut in the bed floor. Place the Eye Bolt (provided) in the threaded hole in the top of the hitch ball and secure it to an overhead lifting device, or to a saw horse in the bed of the truck, and use cable or rope to hold the

(over)

INSTALLATION PROCEDURE - CONTINUED

Ball Assembly firmly against the underside of the bed floor. Fasten the Ball Assembly to the Cross Members with eight 1/2" X 1-1/2" bolts and lock nuts, placing flat washers **ONLY** over the slotted holes. Tighten fasteners in Front Cross Member. Do not fully tighten fasteners in Rear Cross Member at this time.

7. Square the Ball Assembly and Cross Members across the frame. Fasten the Cross Members to the Frame Plates using 1/2" bolts and lock nuts with flat washers over the slotted holes. Pass the 1/2" bolts from between the cross member securing tabs. Do not fully tighten these fasteners at this time.

8. Torque all fasteners to 65 Foot Pounds in following sequence: 1.) Torque the Ball Assembly to both Cross Members. 2.) Torque the Rear U-bolt. 3.) Torque the Cross Members to both Frame Plates. 4.) Torque the Front U-bolt.

9. From the driver side, pass the Actuating Rod (6) through the round 1/2" slotted hole (not the round hole) between the cross member securing tabs and into the linkage coupler. Align the Actuating Rod and insert the set screw so it seats in the hole provided in the rod, and tighten to 7 foot pounds. For adequate clearance where the rod passes, bend the lip formed by the fender and bed floor.

10. Drill four 1/2" holes for the Safety Chain Brackets from under the truck bed. Drill through the **OUTER** four 9/16" holes in the Ball Assembly through the truck bed floor. **Note:** It may be necessary to drill the forward hole on the driver side from the top side of the bed. Center punch a location 2" forward of the center of the rear hole before drilling. Remove all tailings. Place a U-bolt in each pair of holes from the top side of the bed. From under the bed place a spring and 1/2" lock nut on each U-bolt leg. Tighten each nut until thread extends through the nut.

HITCH BALL OPERATION

WARNING: ALWAYS WEAR GLOVES FOR PROTECTION WHEN RAISING OR LOWERING HITCH BALL.

1. Read the **SAFE TOWING INSTRUCTIONS** on your **Warranty Sheet**.

2. Raise and Retract the hitch ball with the Actuating Rod located in the driver side rear wheel well. Raise the hitch ball by firmly pulling the actuating rod to its maximum extension. **Note: Always make certain the hitch ball is fully raised before coupling to a trailer.** When the hitch ball is fully raised, a line cut around the neck of the hitch ball is visible at the tube. Never tow without latching the trailer coupler and attaching safety chains. Retract the hitch ball by pushing the Actuating Rod to its seated position.

3. Retract and Raise the hitch ball frequently. The cam/ball mechanism is best lubricated with a generous spray of WD-40.

4. Insert the Plastic Cap (provided) into the tube for protection from accumulation of debris in the top of the tube when the ball is retracted. The Plastic Cap will pop out when the ball is raised. Protection from debris can also be achieved by leaving the ball in the raised position when a level bed is not required.

5. It may be necessary to remove debris allowed to accumulate in the top of the tube while the hitch ball is retracted and not protected with the Plastic Cap. Insert the Eye Bolt in the ball and lift the ball using a screw driver to displace debris and free the ball.

HARDWARE PROVIDED

- 24 - 1/2" Lock Nuts
- 12 - 1/2" X 1-1/2" Bolts
- 15 - 1/2" Flat Washers
- 2 - 3/8" Plate Washers
- 2 - Safety Chain U-bolts
- 2 - Medium U-bolts
- 2 - Large U-bolts
- 2 - 9/16" springs



Illustration "A"

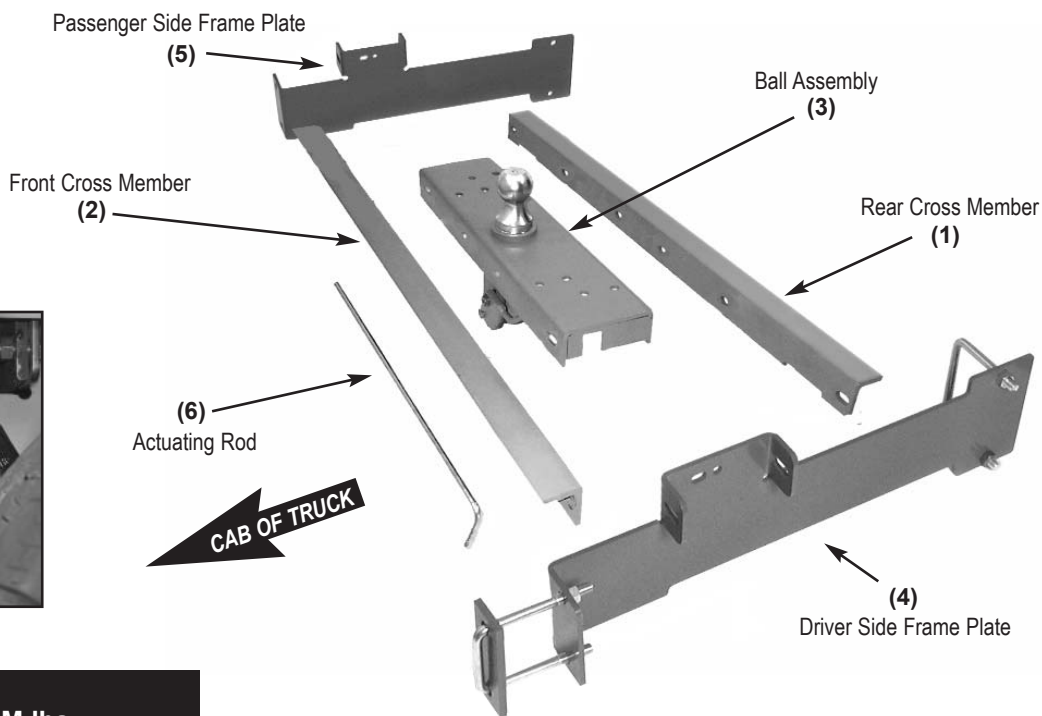

Model Number 120
Gross Trailer Weight: 30M lbs.
Gross Trailer Tongue Weight: 7.5M lbs.