



PopUp Industries, Inc.

## Model 108 R1 Ford Super Duty

Fits 2008

F250 - F350 - F450 w/Factory Bed

2WD & 4WD

## Also Fits

\* 1999 - 2007 \*

F250 & F350

\* 4WD Only \*

## Model 108R1 8-08 FOR THE SAFEST INSTALLATION

**WARNING** Most pick up trucks have **FUEL LINES** and/or **BRAKE LINES** and/or **ELECTRICAL WIRING** positioned along the truck frame rails where our PopUp Hitch will install. **BEFORE INSTALLATION** identify and examine the location of fuel lines, brake lines and electrical wires. Be sure you will not damage fuel lines, brake lines or electrical wiring when positioning the hitch components, drilling holes or tightening fasteners. **Be Certain To Avoid Fuel Tanks When Drilling Holes.**

- Wear Safety Glasses, Gloves and Particle Mask for protection while installing a PopUp gooseneck hitch.
- ALWAYS correctly chock tires prior to raising truck with jacking device. For protection in case of jacking device failure ALWAYS use Jack Stands when working under or around a truck which has been raised by a jacking device.
- Be certain the exhaust system is cool prior to installation to avoid possible burns from hot tail pipe and muffler.
- Torque ALL fasteners used in the PopUp gooseneck hitch installation as specified in these Installation Instructions.

## INSTALLATION PROCEDURE

**WARNING: Verify adequate trailer swing clearance between trailer nose and cab of truck, and trailer and rear of truck.**

1. For both Short and Long Bed trucks, position the Hole in the Truck Bed Floor at **47"** from the rear lip of the truck bed floor. (where the tailgate hinges) Center the hole between the wheel wells, drill hole using a **3" hole saw**.
2. If using a vehicle hoist, raise the truck at this time. If using a jacking device, chock the front tires to prevent the truck from rolling. Lift the rear of the truck approximately 10". It is not necessary to lift the rear tires off the ground. Properly position jack stands under the rear frame of the truck to protect against jack failure.
3. Install the **Rear Crossmember** (the rear angle has a small notch cut out for extra clearance above the exhaust). Slide the angle across lowest part of the frame forward of the hole. Then slide it in position behind the hole. The leg with the holes goes toward the front. Once in place, use a Crescent wrench to turn it up so the leg with the holes is vertical.
4. Slide the **Front Cross Member** across the frame rails forward of the hole for the ball, with the plain side forward and the leg with the holes facing rearward.
5. Screw the 3/8" eye bolt into the top of the ball, raise the Center Assembly into position under the truck bed with the ball tube passing into the 3" hole. Use an overhead lifting device, or a saw horse in the bed of the truck, and cable or rope to hold the Center Assembly firmly against the underside of the bed floor - not so tight as to bow the floor of the truck bed. On some trucks you need to release the rear tailpipe hanger and pull the tail pipe down, install the Center Section then refasten the hanger.
6. Fasten the Center Assembly to the Front and Rear Cross Member 1 1/4" x 1/2" bolts, use flat washers on the oval holes. **Pull the slack out of the bolts but do not tighten at this time.** Square the assembled Cross Members and Center Assembly across the frame.
7. Fasten the Crossmembers to the Frame Plate tangs using 1 1/4" x 1/2" bolts with flat washers and lock nuts. **Pull the slack out of the bolts but do not tighten at this time.** Fasten frame plates to the frame by passing a 3/4" bolt with washer from inside the truck frame through the 3/4" hole in the frame plate and secure with 3/4" nut. Do not tighten at this time.

Install the U-bolts from the inside of the frame with the legs angled down. Leave nuts loose at this time.

CAUTION: Avoid fuel tank, brake lines and/or wiring.

## Follow the torque guidelines listed below.

Tighten the bolts in the following sequence. First tighten the bolts holding the Center Section to the Cross Angles. Release the Center Section from the overhead lifting device. Check to ascertain that the cross angles are resting securely on the frame. Next tighten the Frame Plates to the frame, then Cross Members to the Frame Plate tabs. Now tighten the u-bolts. The tabs on the frame plates may bend in slightly.

8. From the driver side, pass the Actuating Rod thru the slotted hole between the Frame Plate extensions and into the linkage coupler. Align the Actuating Rod so the set screw seats in the hole provided in the rod, and tighten to 7 foot pounds. Be certain the Actuating Rod moves in and out freely.

9. Drill four 1/2" holes for the Safety Chain Brackets from under the truck bed. Drill through the four 9/16" holes in the Center Section through the truck bed floor. Remove all tailings. Place a U-bolt in each pair of holes from the top side of the bed. From under the bed place a spring and 1/2" lock nut on each U-bolt leg. Tighten each nut until thread extends through the nut.

Please read the **SAFE TOWING INSTRUCTIONS** on the PopUp WARRANTY SHEET.

### CAUTION !

Do Not Exceed Load Ratings of Truck or Trailer

## PopUp Industries, Inc.

4330 S. Johnson Road  
Chanute KS 66720  
800-837-8578  
www.popuphitch.com



### HARDWARE PROVIDED

- 12 - 1/2" X 1-1/4" Grd. 8 Bolts
- 16 - 1/2" Lock Nuts
- 8 - 1/2" Flat Washers
- 2 - 6 - 3/8" U-Bolts
- 2 - 3/4" X 2" Bolts & Nuts
- 4 - 3/4" Flat Washers
- 2 - Safety Chain U-Bolts
- 1 - 3/8" Eye Bolt
- 1 - Plastic Cap

### Torque Specifications

- 3/4" Bolts - 70 ft. lbs.
- 1/2" Bolts - 65 ft. lbs.
- 1/2" U-Bolts - 50 ft. lbs.



Model Number 108 R1  
Gross Trailer Weight: 30M lbs.  
Gross Trailer Tongue Weight: 7.5M lbs.

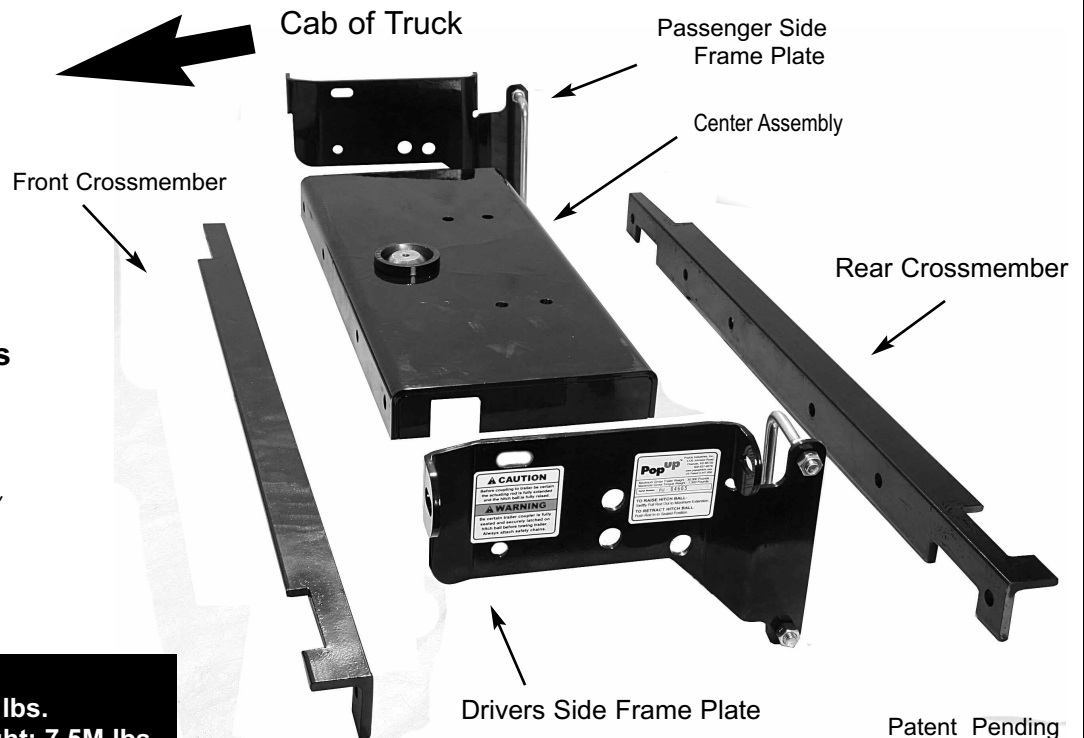

Patent Pending